



Installation instructions

Akrapovič Exhaust System:
Evolution
for the
BMW M5 (type F10)



Installation instructions

Akrapovič Exhaust System:
Evolution
for the
BMW M5 (type F10)

Congratulations on purchasing an Akrapovič exhaust system. Please read the entire installation manual prior to undertaking any activities related to installation of your new Akrapovič exhaust system. In case you do not fully understand the manual or any of its parts, please contact your authorized dealer!

This product should be installed by someone with sufficient knowledge of exhaust systems and their installation, and appropriate hand or power tools. If you are not qualified for this work, please utilize a certified mechanic for installation. By installing Your Akrapovič exhaust system, you indicate that you have read the installation manual in its entirety and you agree with the terms stated herein.

It is your responsibility to follow all installation instruction guidelines supplied with the Akrapovič exhaust system and undertake all necessary safety precautions. Akrapovič d.d. assumes no responsibility for damages occurring from misuse, abuse, improper installation, improper operation, lack of responsible care, or all previously stated reasons resulting from incompatibility with other manufacturer's products and/or systems.

IMPORTANT INFORMATION

Exclusion of Certain Liability

1. The manufacturer, importer or dealer shall not be liable for any incidental damage including personal injury or any other damages caused by improper installation or operation of the Akrapovič exhaust system. When installing the Akrapovič exhaust system be careful that the exhaust system does not touch other parts sensitive to high temperature.
2. Akrapovič makes no representation or warranties with regard to damage caused by the improper installation, use and maintenance of the Akrapovič exhaust system. The warranty is limited to defects recognized by our technical department and due to normal use, and excludes items subject to normal wear (gaskets and damping wool). The guarantee is void in case of accident, modification, improper or competition use.
3. Do not attempt to install the Akrapovič exhaust system on a vehicle model for which it was not made or tested by Akrapovič.
4. When the exhaust system gets very hot during operation, be careful not to burn yourself on the exhaust system or parts which are in direct contact with it, even when the engine is not running. Also protect other people, especially children, from the injuries mentioned above.

1. In some cases Akrapovič exhaust system kits contain chemical products (ceramic anti-seizing grease; bolt sealant). Handle with care, do not inhale or swallow. Avoid excessive contact with skin, eyes or mucous membranes. Keep out of reach of children.
2. Technical specifications of Akrapovič exhaust systems and related products are subject to change without notice.
3. Before removing the original exhaust system from your vehicle, please compare the parts you received with the list of materials provided in the installation manual in order to assure that you have all the parts necessary for the installation of your new Akrapovič exhaust system.
4. Although this manual consists of instructions for installation in written form, as well as photographs and pictures representing individual steps of the installation, please note that the photographs and pictures are symbolic and are intended for representation of general overview only. The photographs and pictures contained herein should serve as a guideline only and actual installation of the exhaust system may not correspond with the photographs and pictures entirely.
5. The process of uninstalling the original exhaust system may vary depending on the existing exhaust system. Please follow the original exhaust system manufacturer's instructions for uninstalling the original exhaust system.

Trademarks

The Akrapovič Exhaust System Technology logo is a registered trademark of Akrapovič d.d.

Akrapovič website

Information about Akrapovič exhaust systems and related products is available on the Akrapovič website at:

<http://www.akrapovic.com/>

Copyright

No part of the Akrapovič exhaust system or its documentation may be reproduced or distributed in any form or by any means without the prior written authorization of the Akrapovič company.

© Akrapovič, d.d. All rights reserved.

Symbols

The following symbols are used throughout these installation instructions:



TOOLS REQUIRED



TIGHTENING TORQUE



INSTALLATION TIP



CAUTION OR WARNING



USE BOLT SEALANT; Apply 3 to 4 small drops of bolt sealant onto the cleaned and degreased threads before tightening the bolts. **WARNING! Avoid contact with skin, eyes and mucous membranes. Do not inhale fumes. Keep out of the reach of children.**



USE ANTI-SEIZE LEAD-FREE COPPER PASTE (black tube); Provides trouble-free and long-lasting protection against seizing, corrosion and rusting of bolts, threaded ends, nuts, joints, etc. Also protects against vibration, wear and impact. **WARNING! Avoid eye contact. Avoid excessive skin contact. Keep out of reach of children.**



USE ANTI-SEIZING GREASE (white tube); Prevents seizing, corrosion and excessive wear between the titanium components of your exhaust system. **WARNING! Avoid eye contact. Avoid excessive skin contact. Keep out of reach of children.**



T-handle swivelling 8 mm wrench
T-handle swivelling 11 mm wrench
Bi-hex 13 mm socket
Bi-hex 15 mm socket
Bi-hex 16 mm socket
Pry bar



BEFORE INSTALLING, CHECK SCHEMATIC OF THE EXHAUST SYSTEM! THE LATEST VERSION OF THE PARTS LIST AND SCHEMATIC DRAWINGS OF THE PRODUCTS ARE AVAILABLE ON OUR WEB PAGE.



IF ANY ITEMS IN THE AKRAPOVIČ EXHAUST SYSTEM PACKAGE ARE MISSING, PLEASE CONTACT YOUR AUTHORIZED DEALER. KEEP THE SCHEMATIC FOR FUTURE REFERENCE.



THESE INSTALLATION INSTRUCTIONS MUST BE READ CAREFULLY IN ORDER TO ENSURE PROPER INSTALLATION AND OPERATION OF THE AKRAPOVIČ EXHAUST SYSTEM.



THE EXHAUST SYSTEM CAN BE EXTREMELY HOT. ALLOW THE EXHAUST AND ENGINE TO COOL DOWN BEFORE BEGINNING INSTALLATION.



WE ADVISE YOU TO LEAVE INSTALLATION TO A QUALIFIED SERVICEMAN. IMPROPER INSTALLATION MAY RESULT IN A SHORTER LIFETIME OF THE EXHAUST SYSTEM AND/OR DAMAGE TO THE VEHICLE.



THIS MANUAL IS SPECIFIC TO THE BMW M5 TYPE F10. THERE MAY BE SOME DIFFERENCES IN INSTALLATION PROCEDURES FOR OTHER MODELS.



AT EACH ENGINE START, THE EXUP VALVES MAY VIBRATE FOR A FEW SECONDS UNTIL THE VACUUM SYSTEM REACHES OPERATING PRESSURE.

REMOVAL OF STOCK EXHAUST SYSTEM:

Put the vehicle onto a car lift.

! **WARNING:** ensure that the car is lifted safely and properly in order to avoid the risk of vehicle damage, injury, or even death!

1. Unscrew all marked bolts and remove the engine's and transmission's protection off the vehicle (Figure 1, 2, 3).

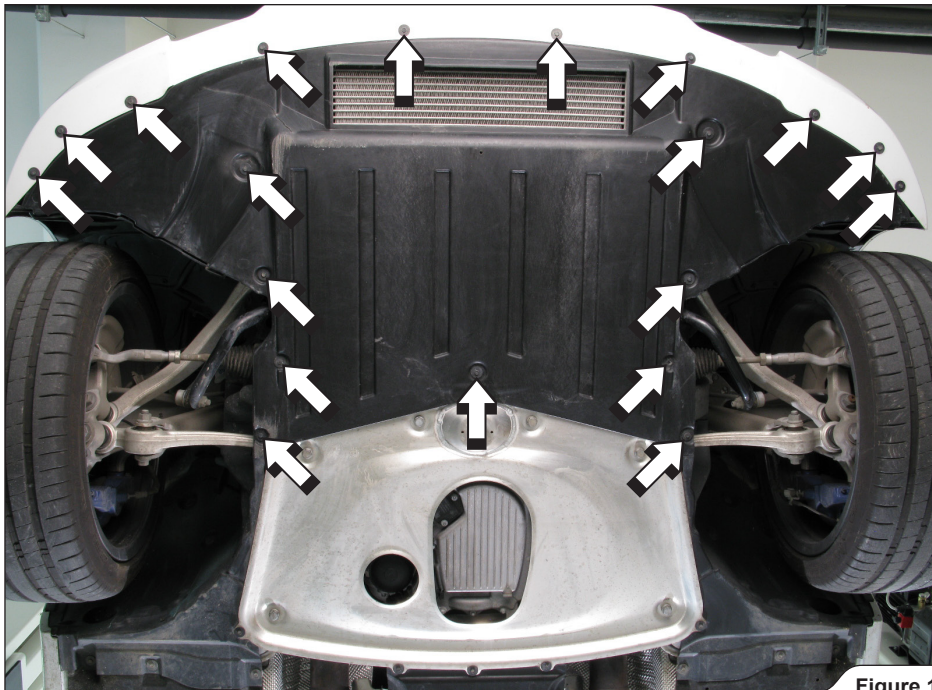

Figure 1

! **WARNING:** make sure not to injure yourself, or damage any part of the vehicle during this procedure!



Figure 2

! **WARNING:** make sure not to injure yourself, or damage any part of the vehicle during this procedure!

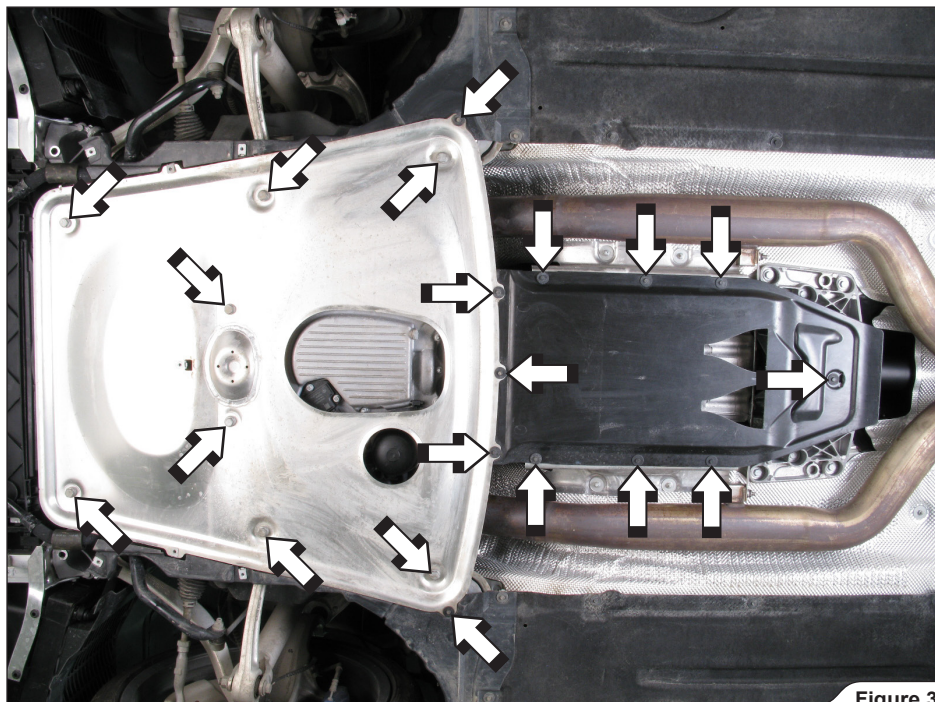

Figure 3

2. Unscrew the marked bolts and nuts. Carefully remove the stock collector's bracket off the vehicle (**Figure 4**).

! **WARNING:** make sure not to injure yourself, or damage any part of the vehicle during this procedure!

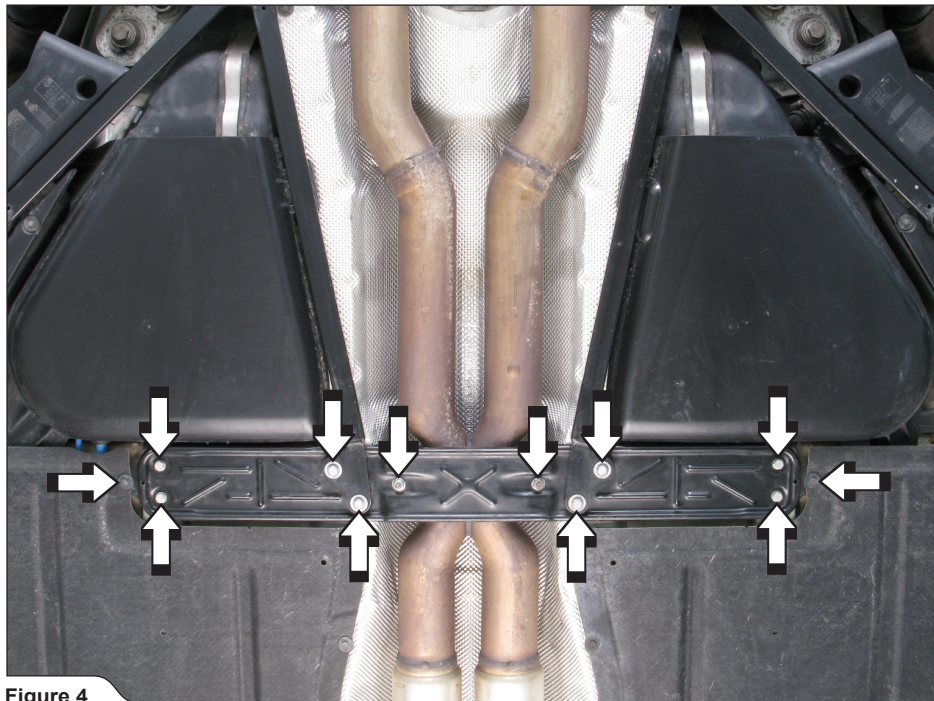

Figure 4

3. Loosen the marked chassis reinforcement bolts on both sides off the vehicle (**Figure 5**).

✂ **INSTALLATION TIP:** loosen the marked bolts only.

! **WARNING:** make sure not to injure yourself, or damage any part of the vehicle during this procedure!



Figure 5

4. Unscrew all marked bolts and carefully remove the differential aluminium protection off the vehicle (Figure 6).

! **WARNING:** make sure not to injure yourself, or damage any part of the vehicle during this procedure!

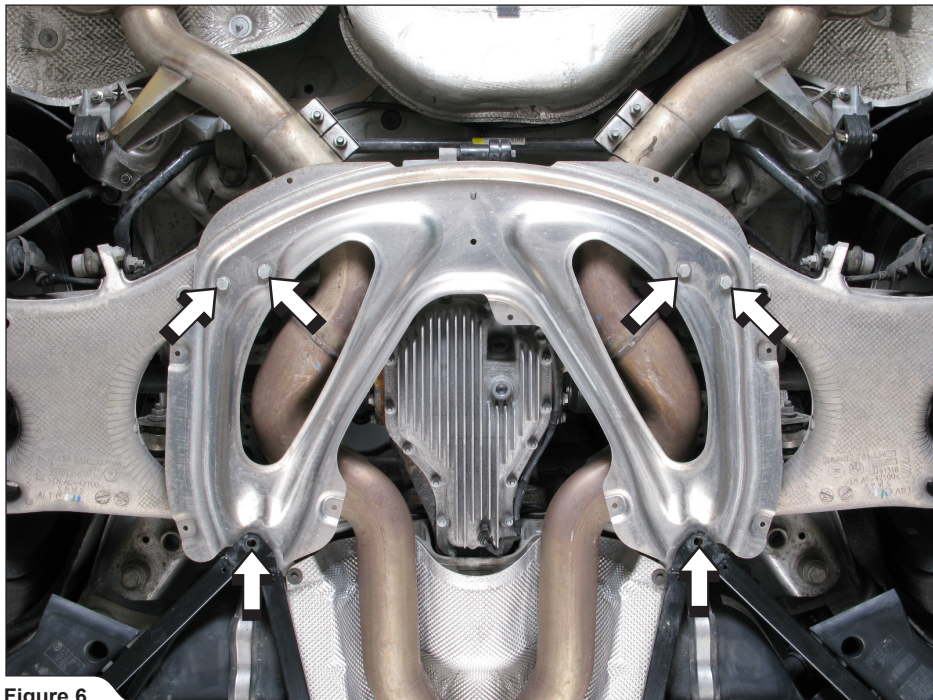

Figure 6

5. Unscrew the marked bolts and remove the link pipes' linkage (**Figure 7**).

! **WARNING:** make sure not to injure yourself, or damage any part of the vehicle during this procedure!

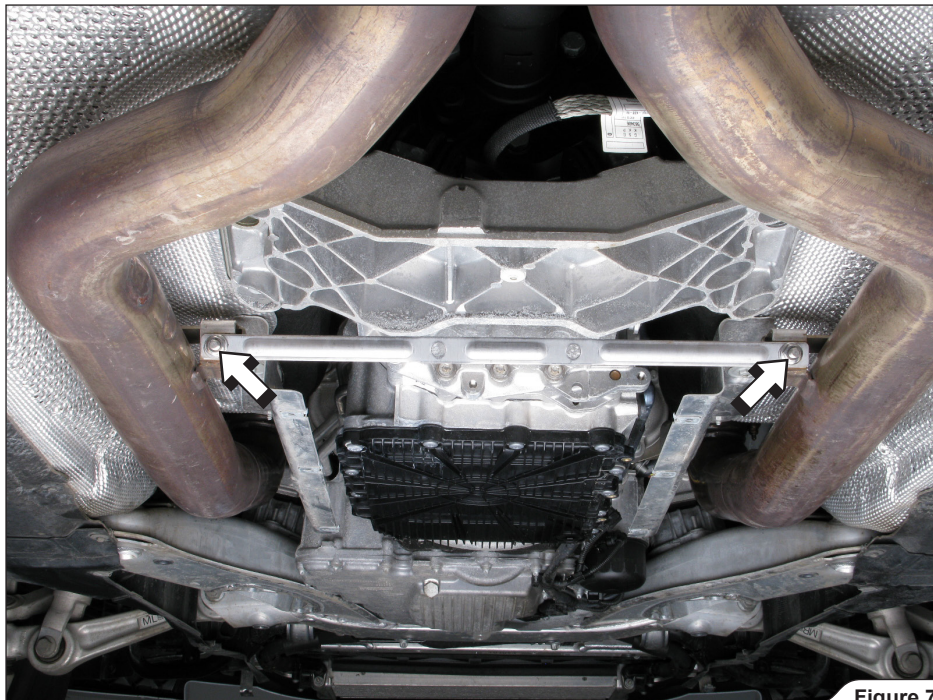

Figure 7

6. Support the stock exhaust system and unscrew the marked flanges' nuts (**Figure 8**).

! **WARNING:** make sure, that you support the exhaust system during this procedure or you could injure yourself or damage the vehicle!

! **WARNING:** make sure not to injure yourself, or damage any part of the vehicle during this procedure!

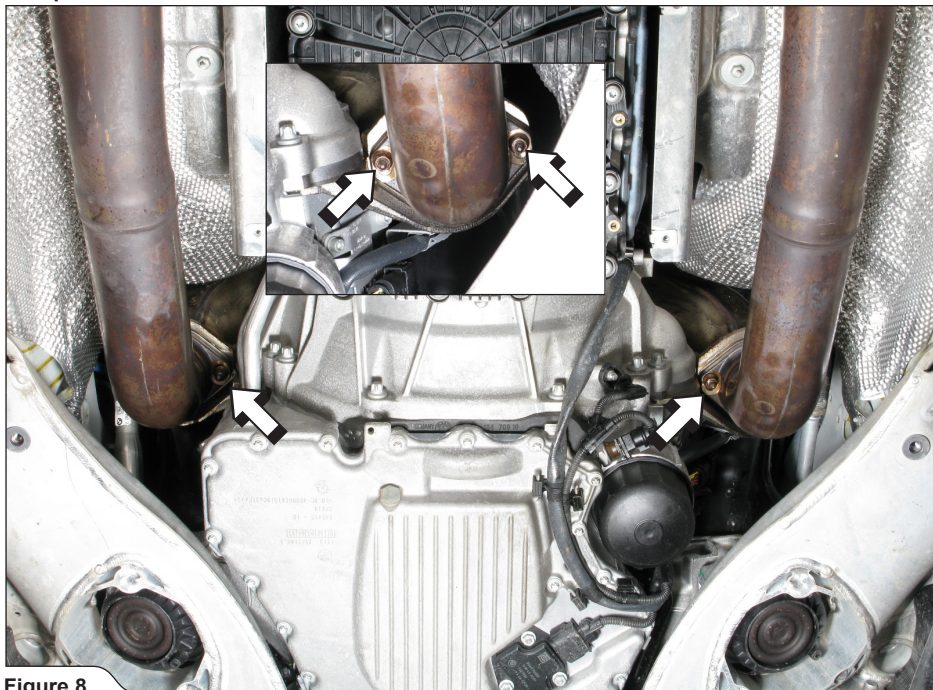

Figure 8

- Carefully pull the vacuum tubes off both vacuum actuators (**Figure 9**).

! **WARNING:** make sure not to injure yourself, or damage any part of the vehicle during this procedure!

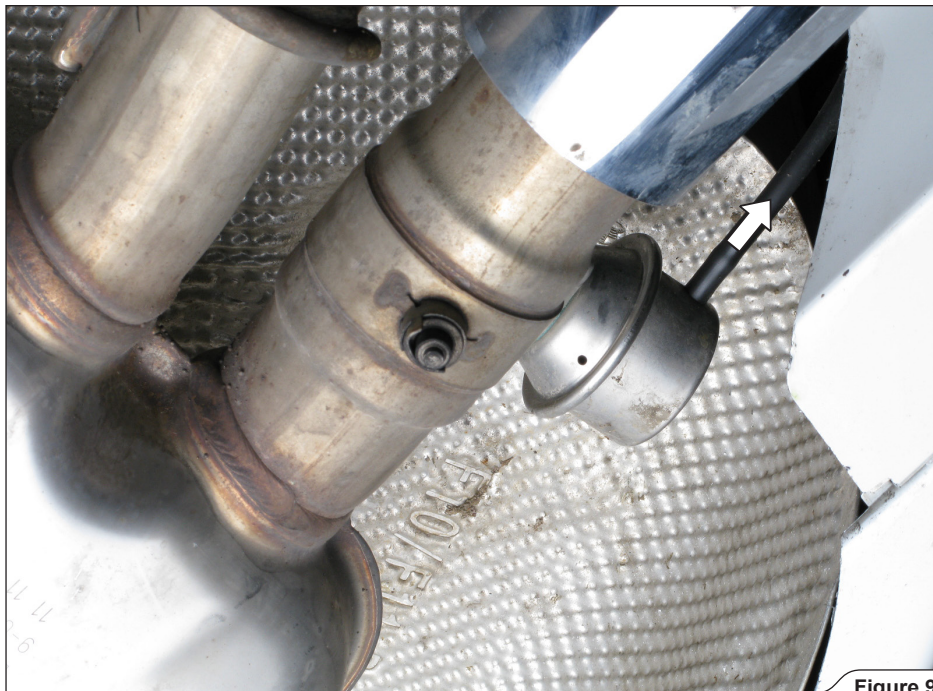

Figure 9

8. Support the stock exhaust system and unscrew all mufflers' brackets (**Figure 10, 11**).
- ! **WARNING:** make sure, that you support the exhaust system during this procedure or you could injure yourself or damage the vehicle!
 - ! **WARNING:** make sure not to injure yourself, or damage any part of the vehicle during this procedure!

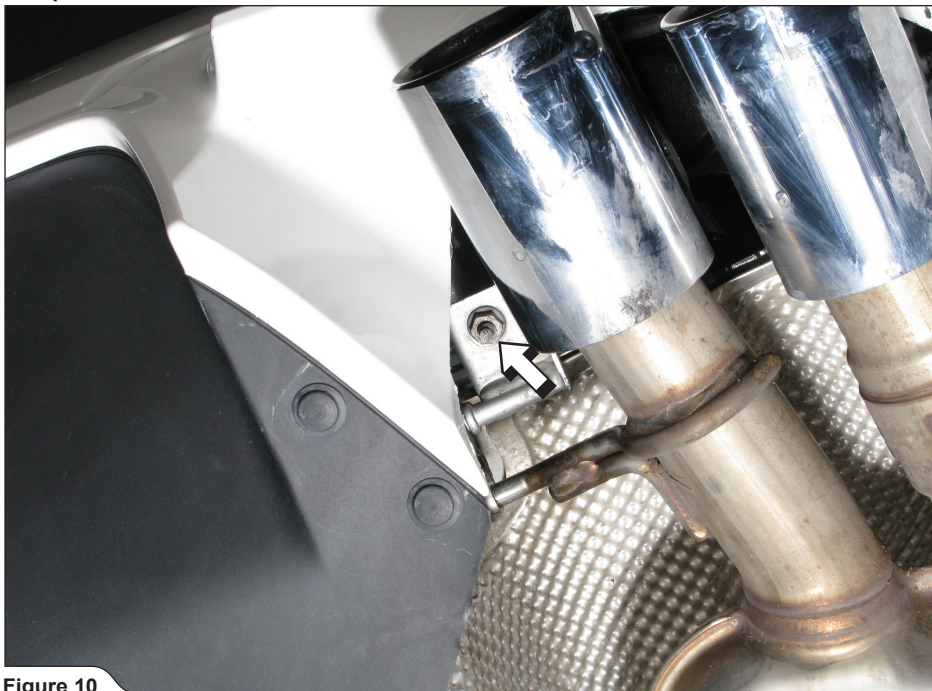

Figure 10

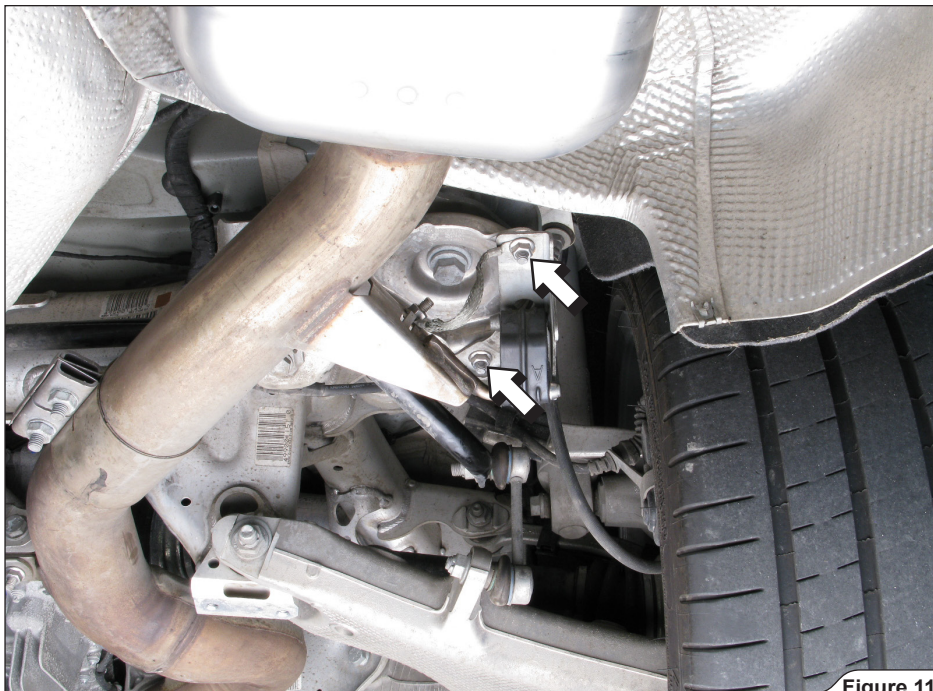

Figure 11

9. Carefully remove the complete stock exhaust system off the vehicle. Carefully pull all rubber brackets off both mufflers and unscrew both ground wires (Figure 12).

! **WARNING:** make sure, not to damage any part of the vehicle during this procedure!
✂ **INSTALLATION TIP:** for easier dismounting, lubricate the original rubber brackets (WD40).

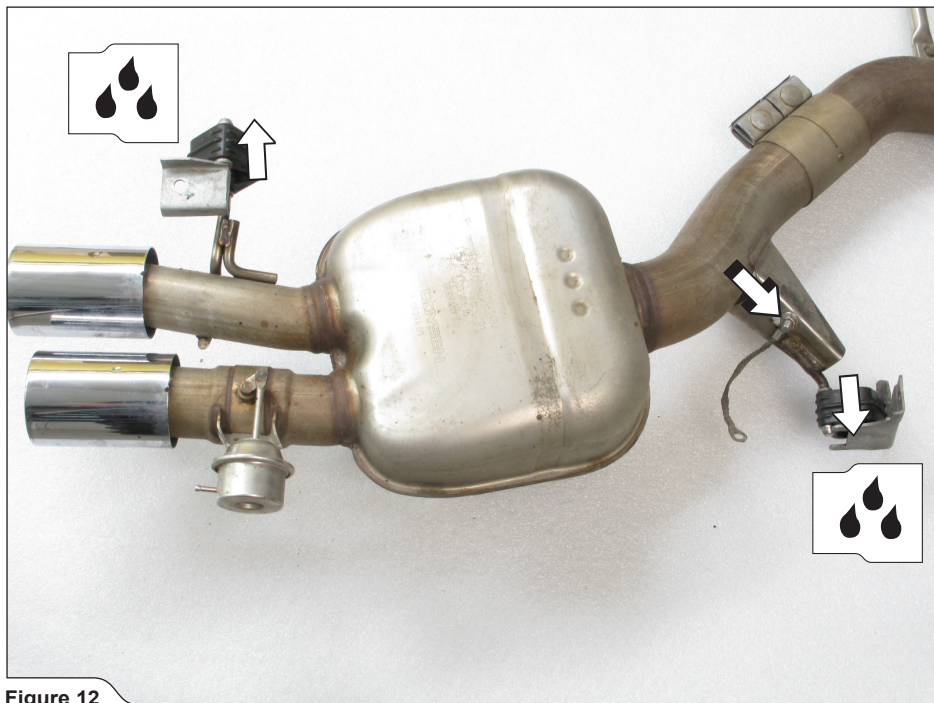

Figure 12

10. Unscrew the marked nuts and remove the rubber brackets off the collector (**Figure 13**).

! **WARNING:** make sure not to injure yourself, or damage any part of the vehicle during this procedure!

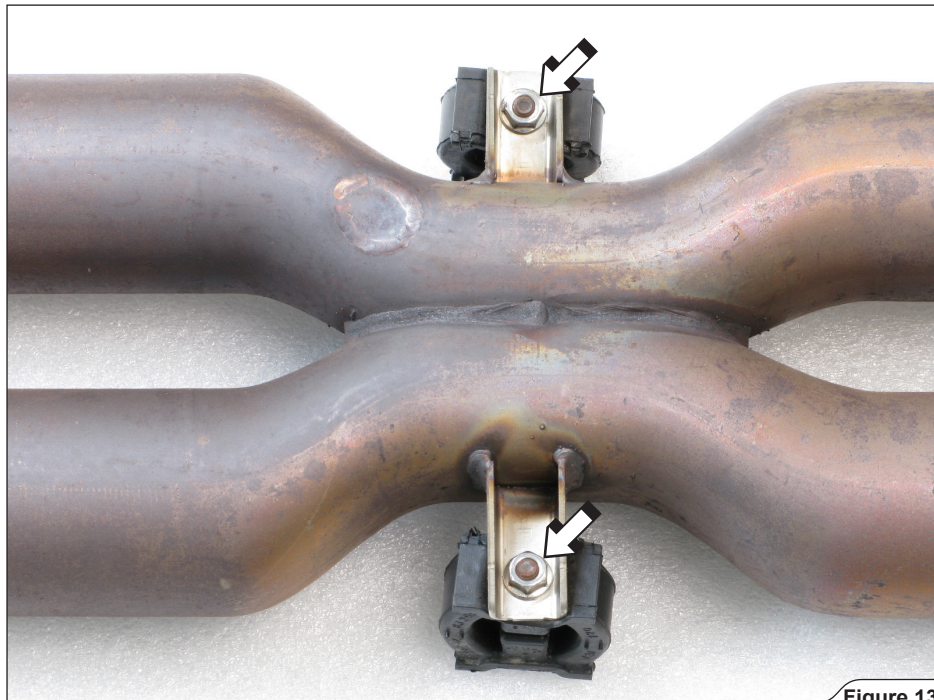

Figure 13

INSTALLATION OF THE AKRAPOVIČ EXHAUST SYSTEM:

1. Correctly orient and attach the clamps (from Akrapovič installation kit), stock rubber brackets and stock ground wires (using M8x16mm bolts from Akrapovič installation kit) onto both mufflers (Figure 14, 15, 16).

! **WARNING: use anti-seize copper paste on clamps' bolts and nuts threads!**

! **WARNING: do not fully tighten the clamps yet!**



Figure 14

W **INSTALLATION TIP:** for easier mounting, lubricate the original rubber brackets (WD40).



Figure 15

 **INSTALLATION TIP:** for easier mounting, lubricate the original rubber brackets (WD40).

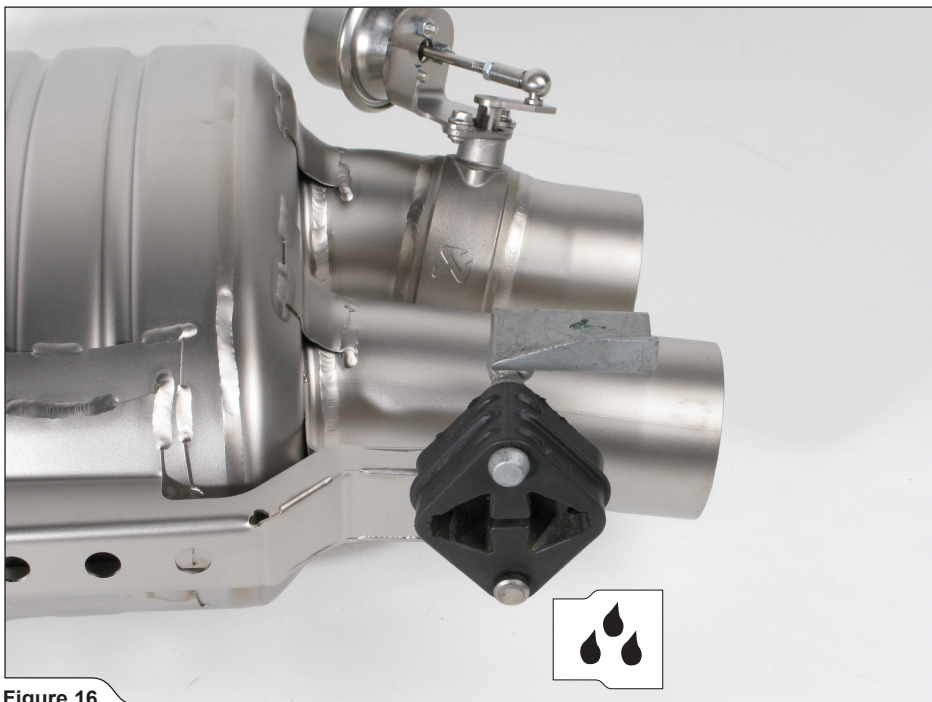
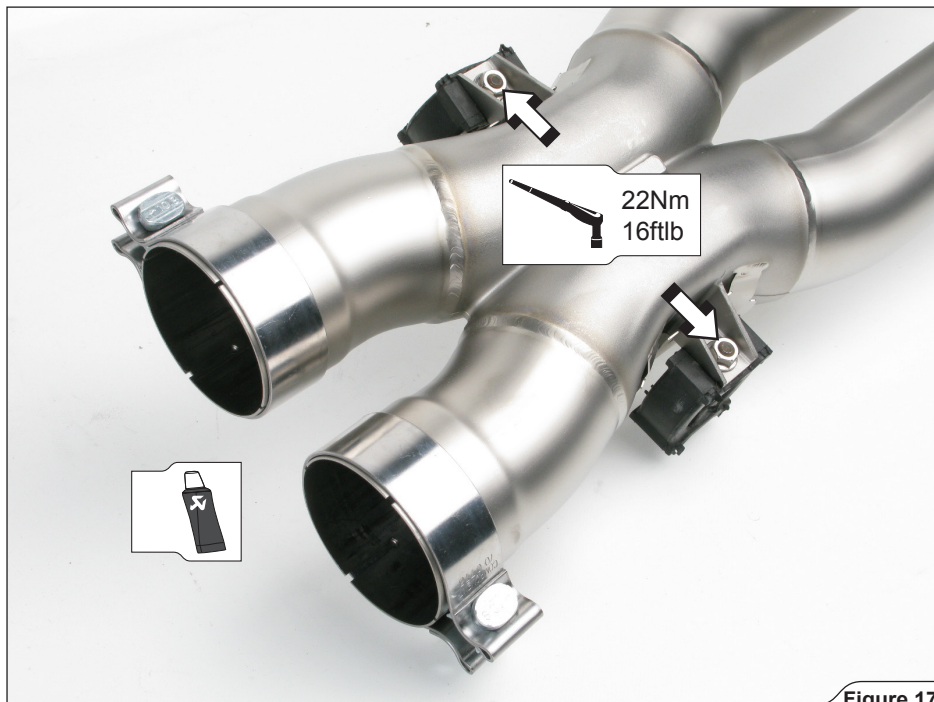

Figure 16

2. Correctly orient and attach the clamps (from Akrapovič installation kit) and stock rubber brackets (using stock nuts) onto the Akrapovič collector, as shown (Figure 17).

! **WARNING: use anti-seize copper paste on clamps' bolts and nuts threads!**

! **WARNING: do not fully tighten the clamps yet!**



3. Attach the stock linkage onto the link pipes, using M8x16mm bolts from Akrapovič installation kit (Figure 18).

! **WARNING:** do not fully tighten the bolts yet!



Figure 18

- Carefully attach the Akrapovič link pipes onto the stock down pipes, using stock nuts (**Figure 19, 20**).

! **WARNING:** make sure, that you support the link pipes during this procedure or you could injure yourself or damage the vehicle!

! **CAUTION:** use new stock exhaust gaskets in link pipes - down pipes joints!

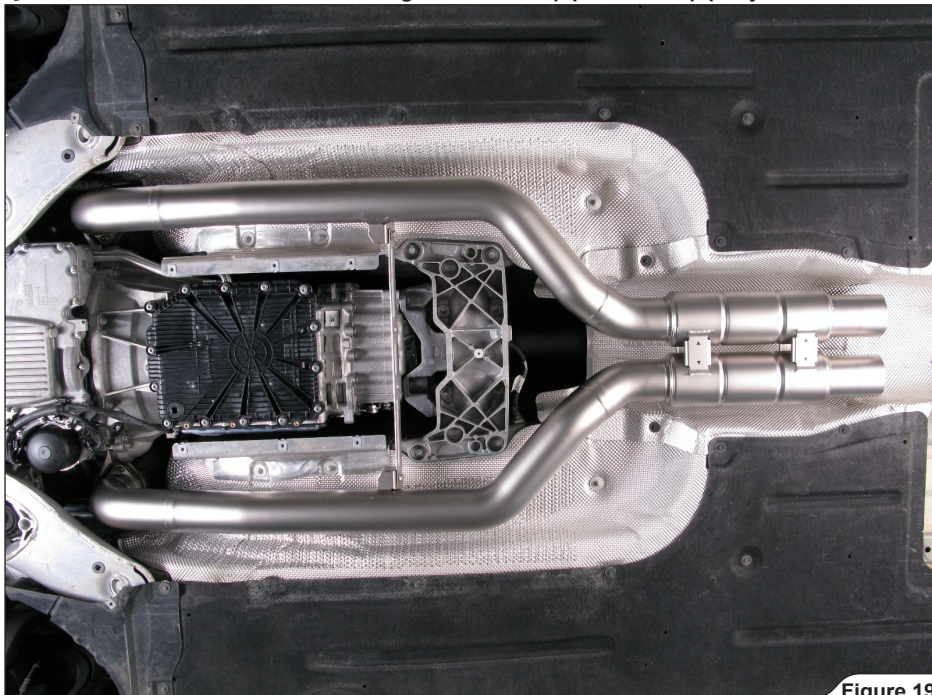

Figure 19

! WARNING: do not fully tighten the link pipes yet!

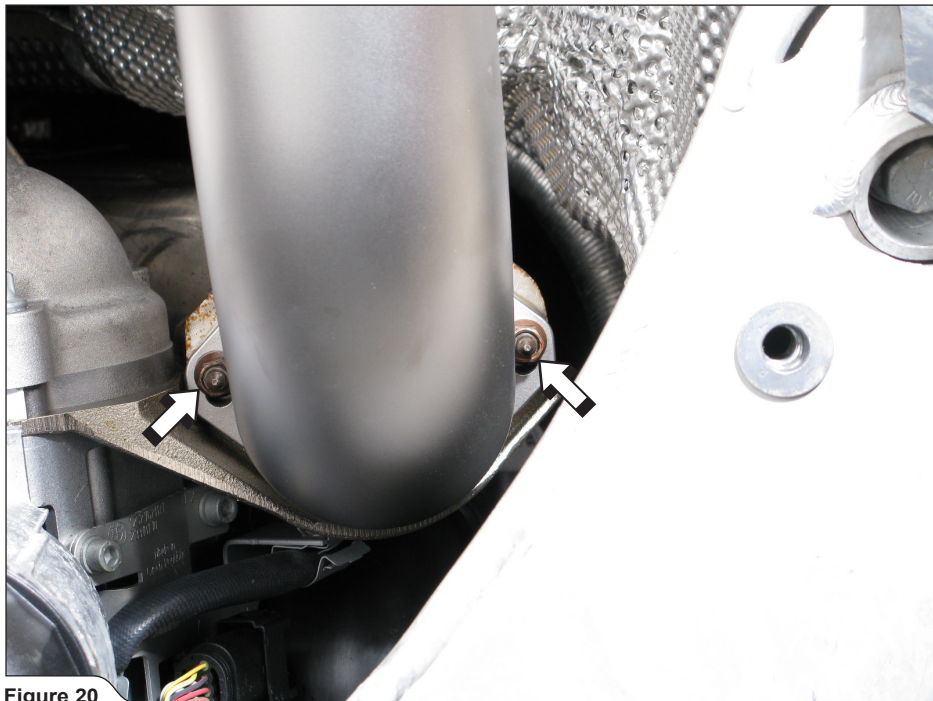

Figure 20

5. Slide the collector all the way onto the link pipes and tighten the clamps (**Figure 21**).

! **WARNING:** make sure, that you support the link pipes and collector during this procedure or you could injure yourself or damage the vehicle!

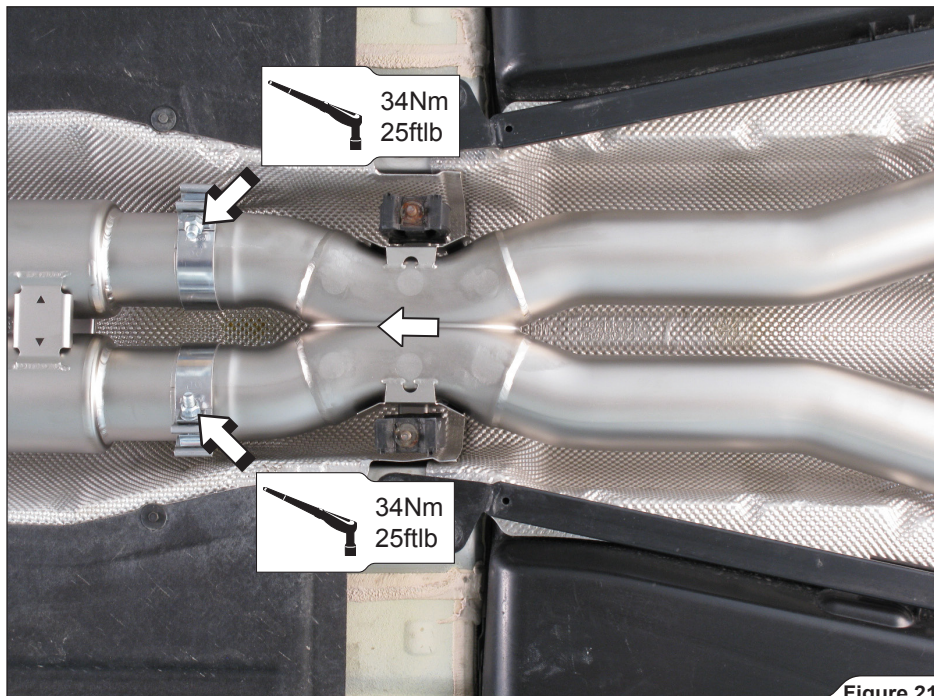

Figure 21

- Carefully attach stock collector's bracket onto the vehicle, and hand tighten all the stock bolts and nuts (**Figure 22**).

! **WARNING:** do not fully tighten any of the bracket's bolts and nuts yet!

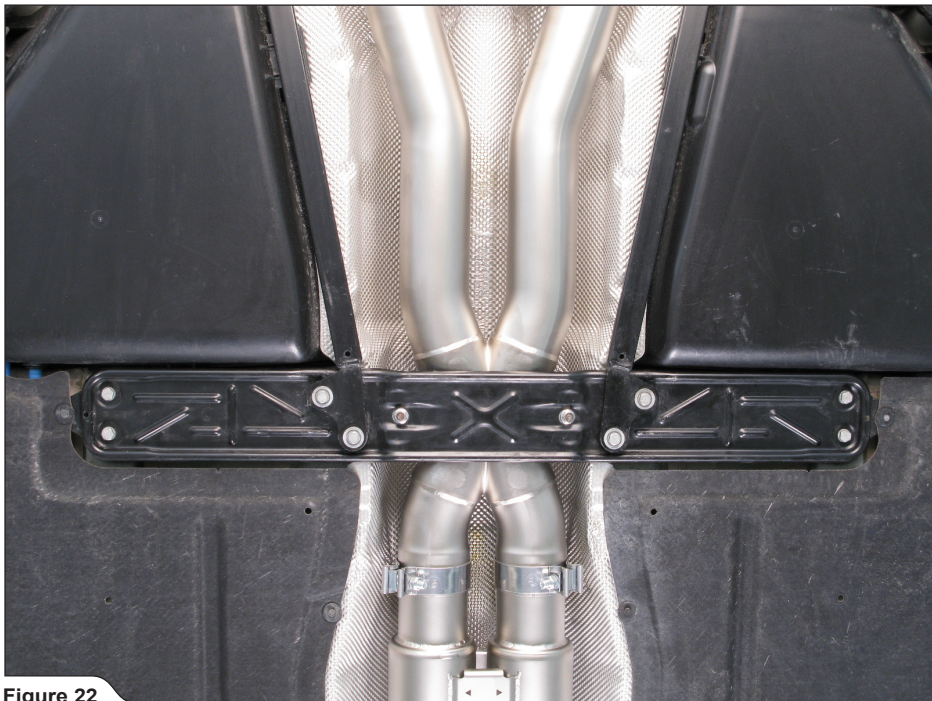

Figure 22

- Slide both mufflers all the way onto the collector's outlets, tighten all stock rubber brackets (using stock nuts) onto the chassis, center the mufflers in respect to the rear bumper's tail pipe outlets and tighten the clamps (**Figure 23, 24**).

! **WARNING:** make sure not to injure yourself, damage any part of the vehicle or exhaust system during this procedure!

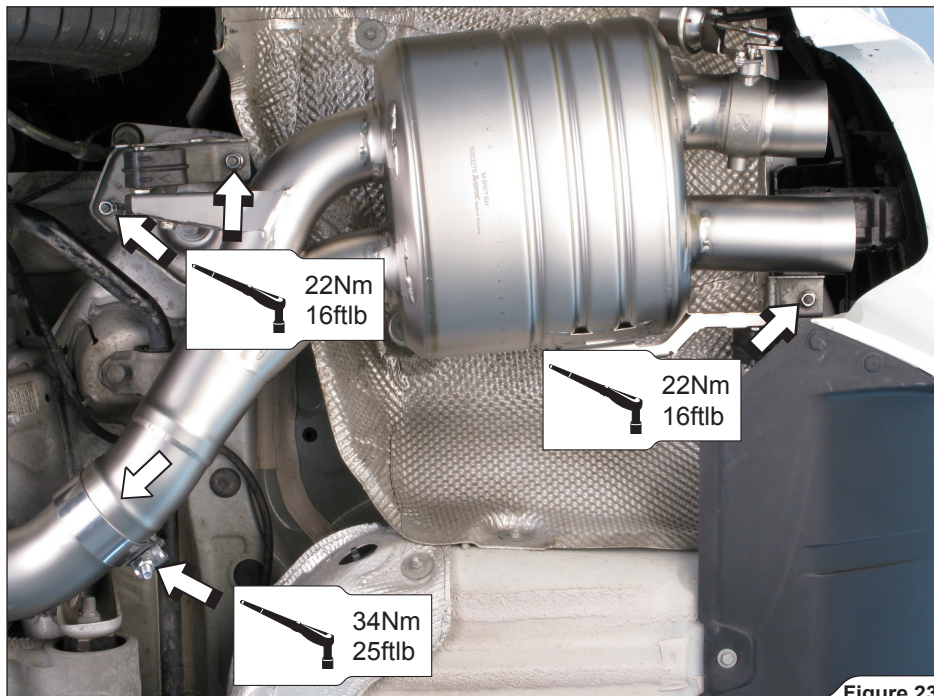

Figure 23

! CAUTION: attach the stock ground wires onto the chassis on both sides of the vehicle!

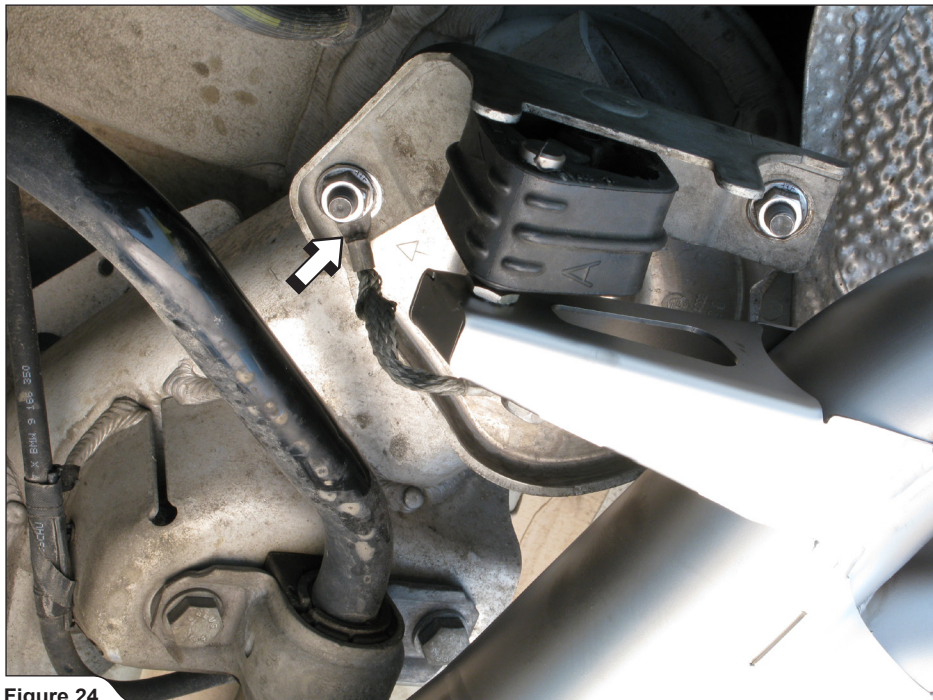

Figure 24

8. Link the stock vacuum hoses onto vacuum actuators on both mufflers (**Figure 25**).



Figure 25

9. Center the mufflers in respect to the rear bumper's tail pipe outlets and chassis, than tighten the collector's linkage, using bolts and nuts from Akrapovič installation kit (**Figure 26**).

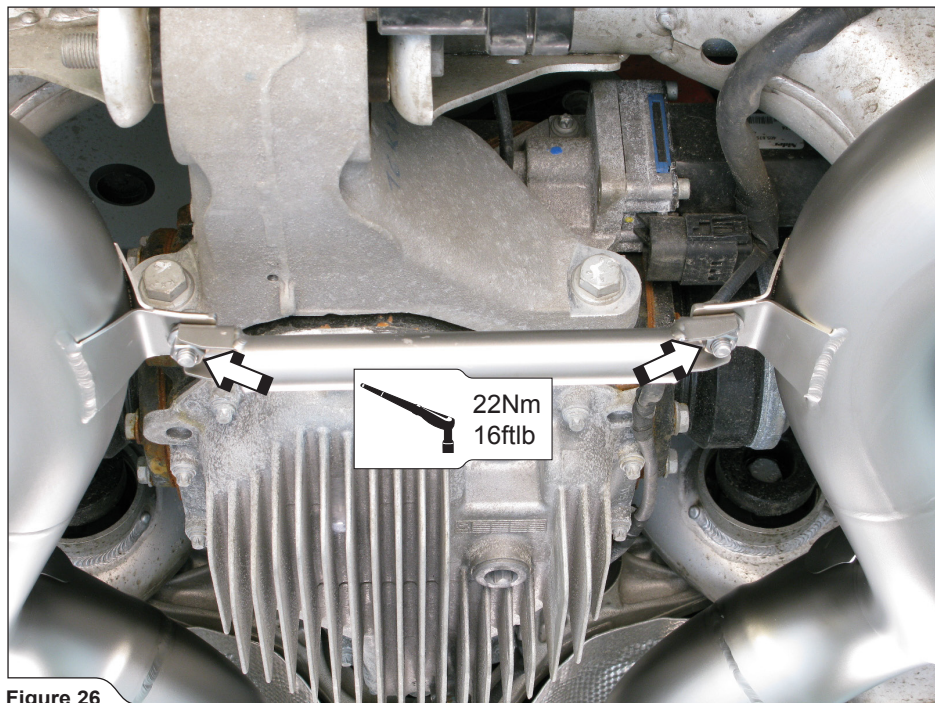

Figure 26

10. Tighten the flange nuts and link pipes linkage bolts to the specified torque (**Figure 27**).

! **WARNING:** make sure not to injure yourself, damage any part of the vehicle or exhaust system during this procedure!

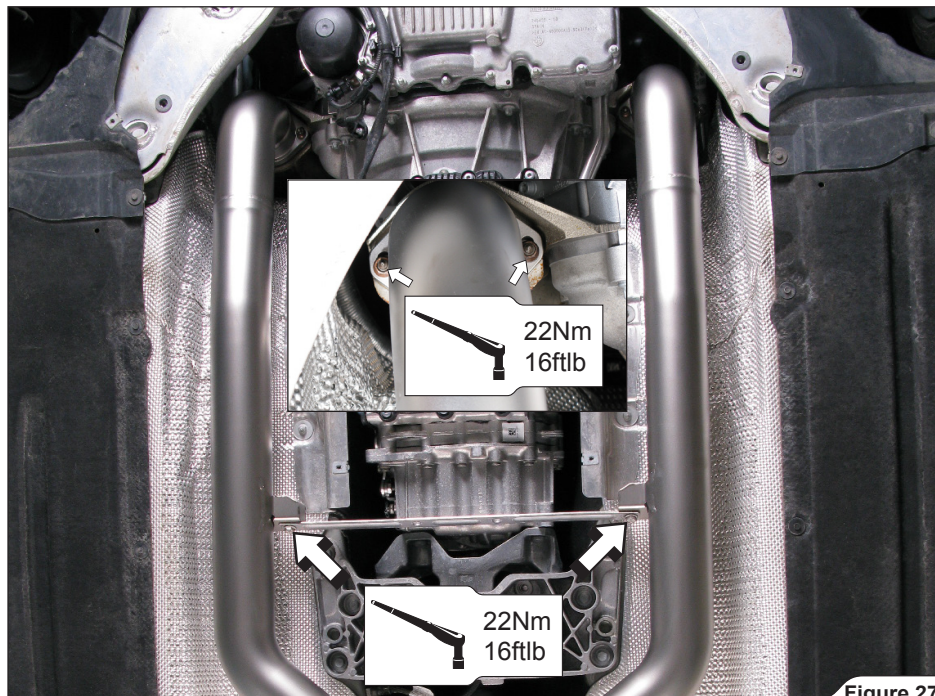

Figure 27

11. Replace all dismantled original parts (differential aluminium protection, collector bracket, chassis reinforcements, engine/transmission aluminium and PVC shields) in the reverse order from the order in which they were removed. Check vehicle manufacturer manual for tightening torques.

! **WARNING: make sure not to injure yourself, damage any part of the vehicle or exhaust system during this procedure!**

12. Assemble the clamps and spherical rings onto the tail pipes, as shown (Figure 28).

! WARNING: use anti-seize copper paste on clamp bolt threads!



Figure 28

- Slide the tail-pipes onto the muffler outlets. Rotate and center them in respect to rear bumper and according to your personal taste (Figure 29, 30).

! **WARNING:** make sure, not to damage tail pipes, bumper or any other part of the vehicle during this procedure!



Figure 29



Figure 30

14. Tighten tail pipe clamps to the specified torque on both sides of the vehicle (**Figure 31**).

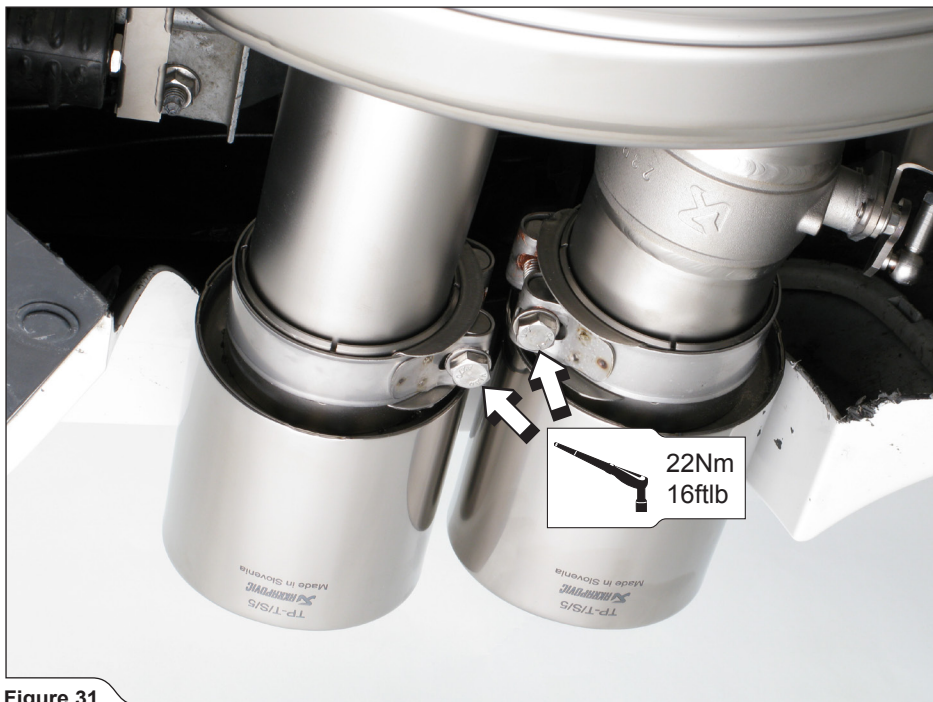

Figure 31

Final installation:

- ! **WARNING: check vehicle manufacturer manual for tightening torques (for dismantled stock parts)!**
- ! **WARNING: make sure all the nuts and bolts are sufficiently tightened. In case the exhaust system touches the cowling or other parts, repeat the adjustment of the exhaust system or contact your authorized dealer.**

MAINTENANCE OF THE AKRAPOVIČ EXHAUST SYSTEM:

1. Clean the titanium exhaust components with a multi-purpose spray lubricant (WD-40 or equivalent), carbon fiber exhaust components with soft and dry cloth and stainless steel components with soft cloth sprayed with contact cleaner, then wipe with soft and dry cloth. A change in the color of the exhaust system is normal due to high temperatures.
2. Periodically make sure all the bolts and springs are sufficiently tight.

! **WARNING: clean all exhaust components before the first start of the engine or the stains will burn onto the surfaces!**

! **IT IS NORMAL FOR WHITE SMOKE TO COME OUT OF THE MUFFLER AT FIRST OPERATION.**

! **DO NOT STAND BEHIND THE MUFFLER AT FIRST OPERATION.**

! **DO NOT USE AUTOMOTIVE WHEEL CLEANERS OR ANY CLEANING PRODUCTS WHICH CONTAIN ACIDIC ADDITIVES TO CLEAN THE AKRAPOVIČ EXHAUST SYSTEMS.**

WARNING

Please note that certain aftermarket exhaust systems may not comply with applicable California laws and regulations, and may therefore be prohibited for use on California highways or roads, or on roads or vehicles otherwise subject to emissions control requirements.

Akrapovič exhaust systems for automobiles and motorcycles mounted downstream of the catalytic converter (also known as “cat-back systems”) are considered “replacement parts” in California by the California Air Resources Board (CARB), and do not require an exemption or executive order from CARB to be sold in California. However, California prohibits the use of any aftermarket exhaust system that modifies, removes or replaces original equipment catalysts, unless CARB has issued an Executive Order as to such part or system.

Further, Akrapovič parts or exhaust systems used or intended for use on “racing vehicles” (i.e. a competition vehicle used exclusively for competition on closed-course circuits) do not require an exemption or Executive Order from CARB to be sold in California. However, such parts are prohibited from use on California public highways or roads, even if occasionally used “off-road.”

www.akrapovic.com

